

INPUT SHAFT PROJECTION -1  
 BOTH ENDS PROJECTION -3  
 INPUT SHAFT PROJECTION -2

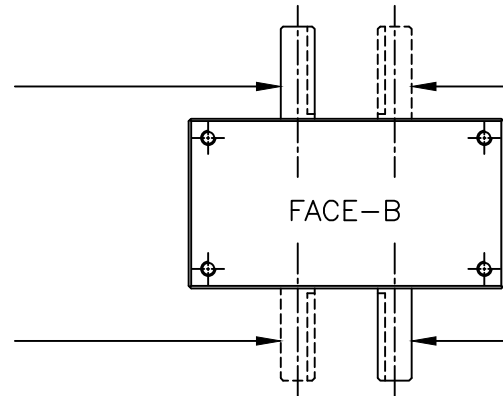

OUTPUT SHAFT PROJECTION -7  
 BOTH ENDS PROJECTION -9  
 OUTPUT SHAFT PROJECTION -8

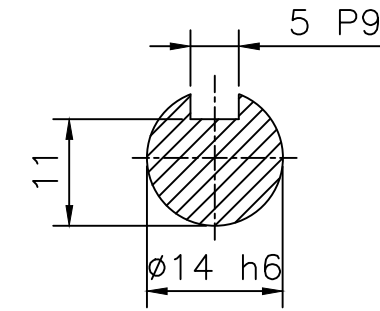

INPUT & OUTPUT SHAFT KEYWAY

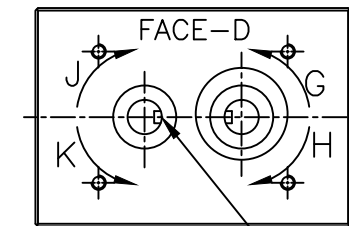
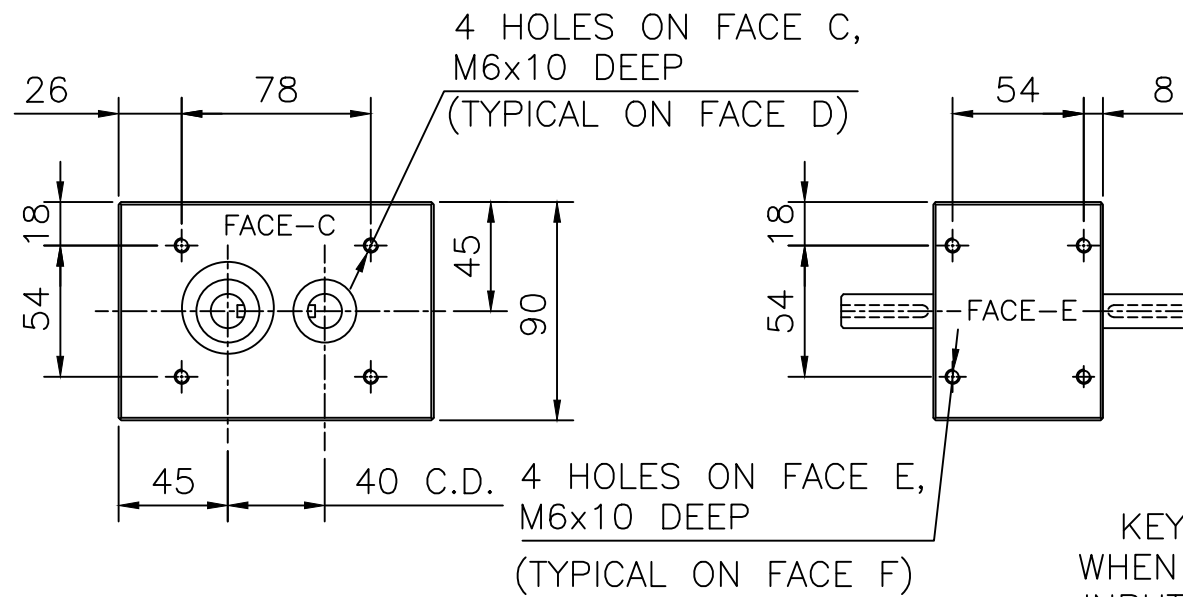
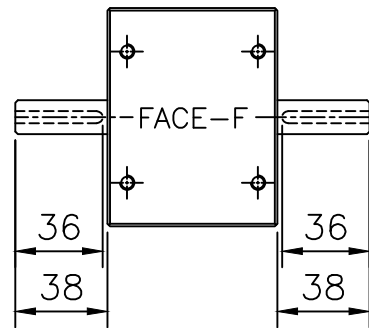

KEYWAY WILL BE IN THIS POSITION WHEN CAM IS IN CENTRE OF DWELL. INPUT SHAFT MAY ROTATE IN EITHER DIRECTION & PRODUCES OPPOSITE OUTPUT SHAFT ROTATION

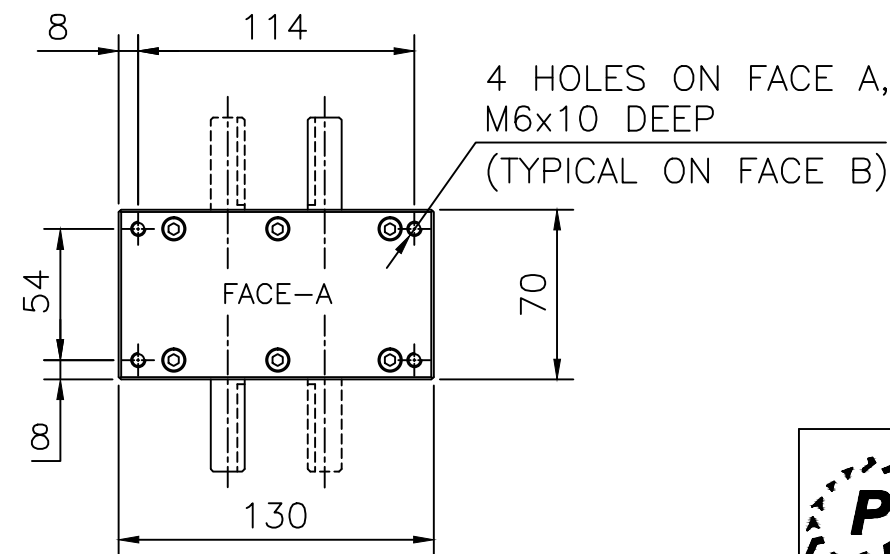

- NOTES :
- 1) MOUNTING POSITION AND MOUNTING FACE IS TO BE DEFINED BEFORE ORDERING.
  - 2) DIRECTION OF ROTATION OF OUTPUT SHAFT IS OPPOSITE TO THE DIRECTION OF ROTATION OF INPUT SHAFT.
  - 3) SHAFT PROJECTIONS 1 & 8 ARE STANDARD.

ALL DIMENSIONS ARE IN mm UNLESS OTHERWISE SPECIFIED



PACKAM CONTROLS PRIVATE LIMITED

PREMIUM PACKAM SERIES  
 STD INSTALLATION DRG-PC40-S (SHAFT TYPE)

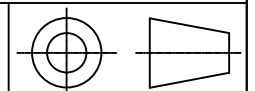

DRAWN BY PMB	CHECKED BY SN	DATE 03.08.16	SCALE ~	DRAWING No. PC040S-H-S-001-X	ISSUE 2
-----------------	------------------	------------------	------------	---------------------------------	------------

KINDLY CONTACT PACKAM FOR LATEST VERSION