

# TIMING CAM & SENSOR

## Sensor

## Mounting Bracket

**OMRON**

M12 Size  
Pre-wired Models (Shielded)  
Short Body

MODEL: E2B-M12KS02-WP-B1 2M

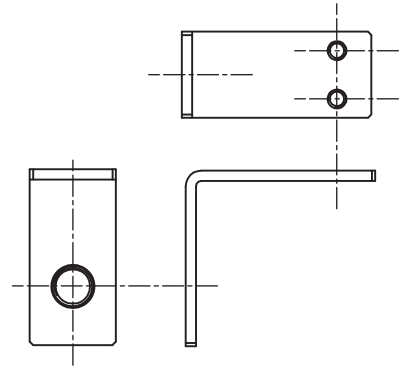
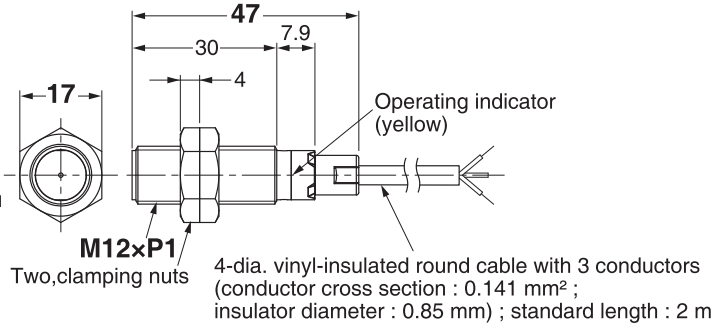

Standard sensor supplied with package for cycle-on-demand (start-stop) applications

### WARNING

DO NOT START / STOP  
WHEN IN INDEX

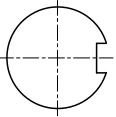

KEYWAY WILL BE IN THIS POSITION WHEN CAM IS IN CENTRE OF DWELL

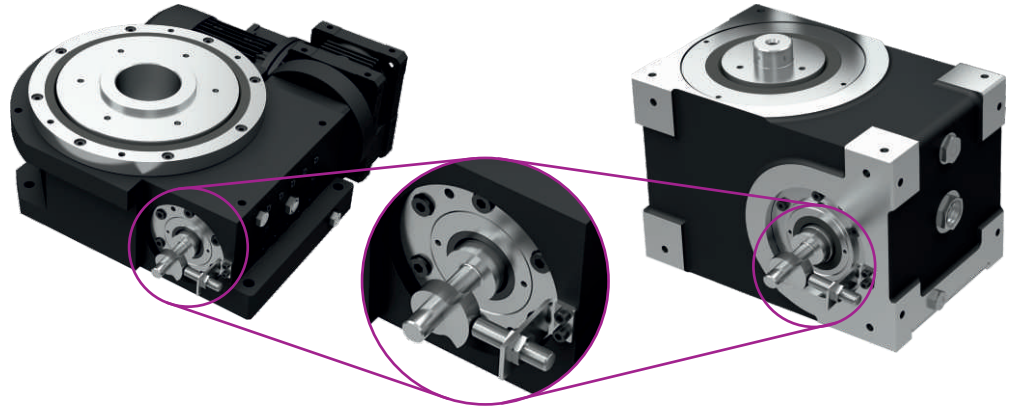

## Sensor & Mounting Bracket Assembly

KEYWAY WILL BE IN THIS POSITION WHEN CAM IS IN CENTRE OF DWELL

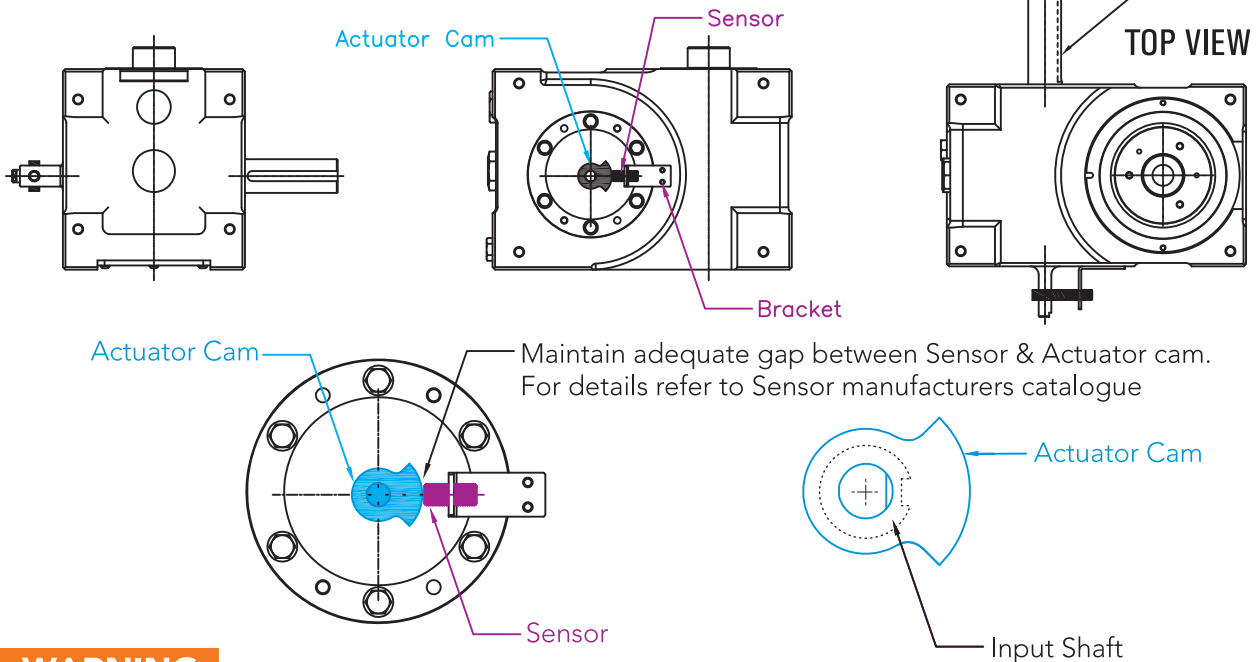

### WARNING

INSTALLATION OF THIS MUST BE DONE BY SKILLED PERSONNEL ONLY. FAILURE TO FOLLOW THESE INSTRUCTIONS CAN RESULT IN EQUIPMENT DAMAGE.