

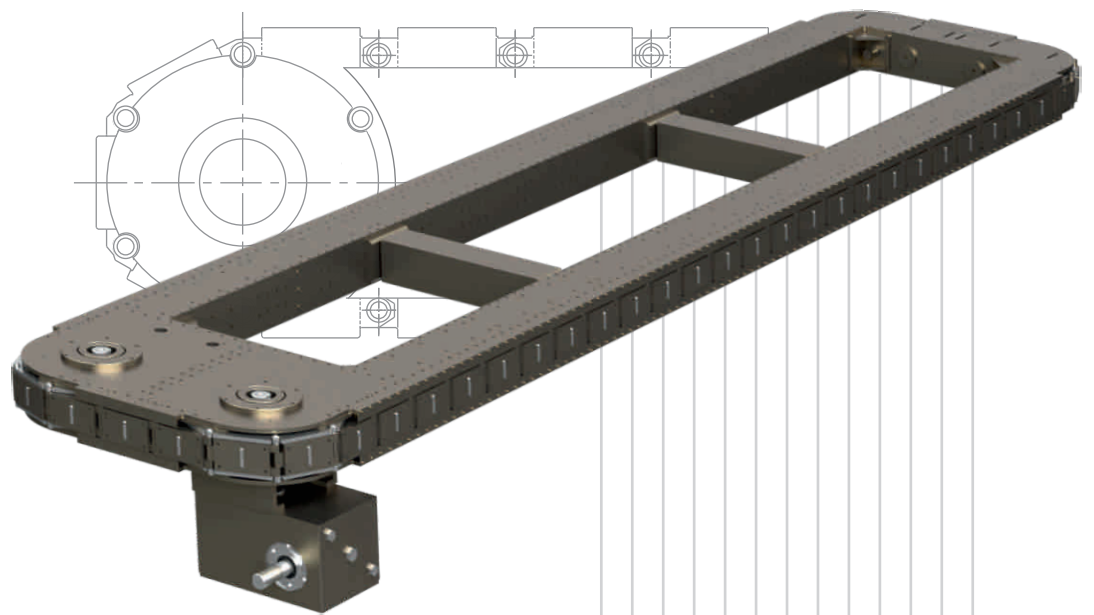

EN ISO 12100:2010

WIDE-BODY CONVEYOR

PREMIUM PACKAM SERIES



WIDE-BODY PRECISION LINK CONVEYORS

The LR series of precision link conveyor is an excellent choice for a robust, accurate linear assembly chassis.

Precision machined steel links are accurately advanced with either a fixed motion cam indexer or a servo driven. Our robust steel conveyor frame preloads the links in all directions. An innovative wide-body design provides adequate space for mounting of robotics and fixtures.

These conveyors are most suitable for high-speed assembly of components — especially when there are high part counts or complicated assembly processes. Work processes are usually performed along the conveyor's linear sections. Most useful for manufacturing tasks for aerospace, solar and wind energy, automotive, defence, electronics, consumer goods, and medical devices, precision link conveyors are fast and accurate in positioning to allow assembly (and other tasks) on up to 150 parts per minute.

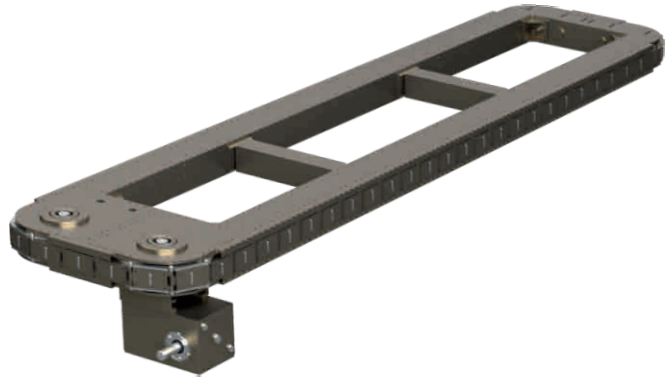

LR Type

CE Certified Product - EN ISO 12100:2010

Selection Criteria: LR Type

Models:

LR200

Sold complete with Indexer + Geared Motor Package.

Mechanism Type: Globoidal

Mounting Arrangement: Caesural

Features:

- Higher accuracy and repeatability as compared to any other brand available in the market
- Polygonal effect compensation cams
- Through hardened CNC ground cams – ensures accuracy & long life
- Precision Cam followers ensures accuracy & durability
- Holds accuracy longer due to self-lubricating bush in links
- Driven by Packam's Ultra Precise Globoidal Cam Indexer ensuring highest quality & performance
- Packam Index Drive offers low peak acceleration and a smooth index.
- Electro less Nickel Plates (ENP) to avoid corrosion and for clean room applications
- High Speed Up To 150 Cycles Per Minute
- All Links Are Preloaded in X, Y, and Z Axis for ZERO Backlash
- High Load Capacity as compared to other conveyors
- Serve as the main chassis when multiple components are assembled
- Reconfigurable lengths to match product size or increased production
- Easy synchronization of other mechanical devices

Indexes/minute: <150

Direction of rotation: Clockwise, counter clockwise

Accuracy: Refer to model specific page in our Technical Product Catalogue

**ZERO
BACKLASH**



**HIGH ACCURACY
AND
REPEATABILITY**



Lubed for Long Life



CE
EN ISO 12100:2010



**LONG
LIFE**

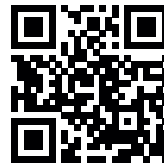

Packam Controls Private Limited
Patel Vanika, Western Express Highway,
Goregaon (East), Mumbai - 400 063, India

T +91 22 61206600
F +91 22 61206606

E info@packam.co.in
U www.packam.co.in

Domestic Sales Enquiry sales@packam.co.in
International Sales Enquiry export@packam.co.in
After Sales Service service@packam.co.in

