



South Asia



EN ISO 12100:2010

CAM INDEXERS

PREMIUM PACKAM SERIES

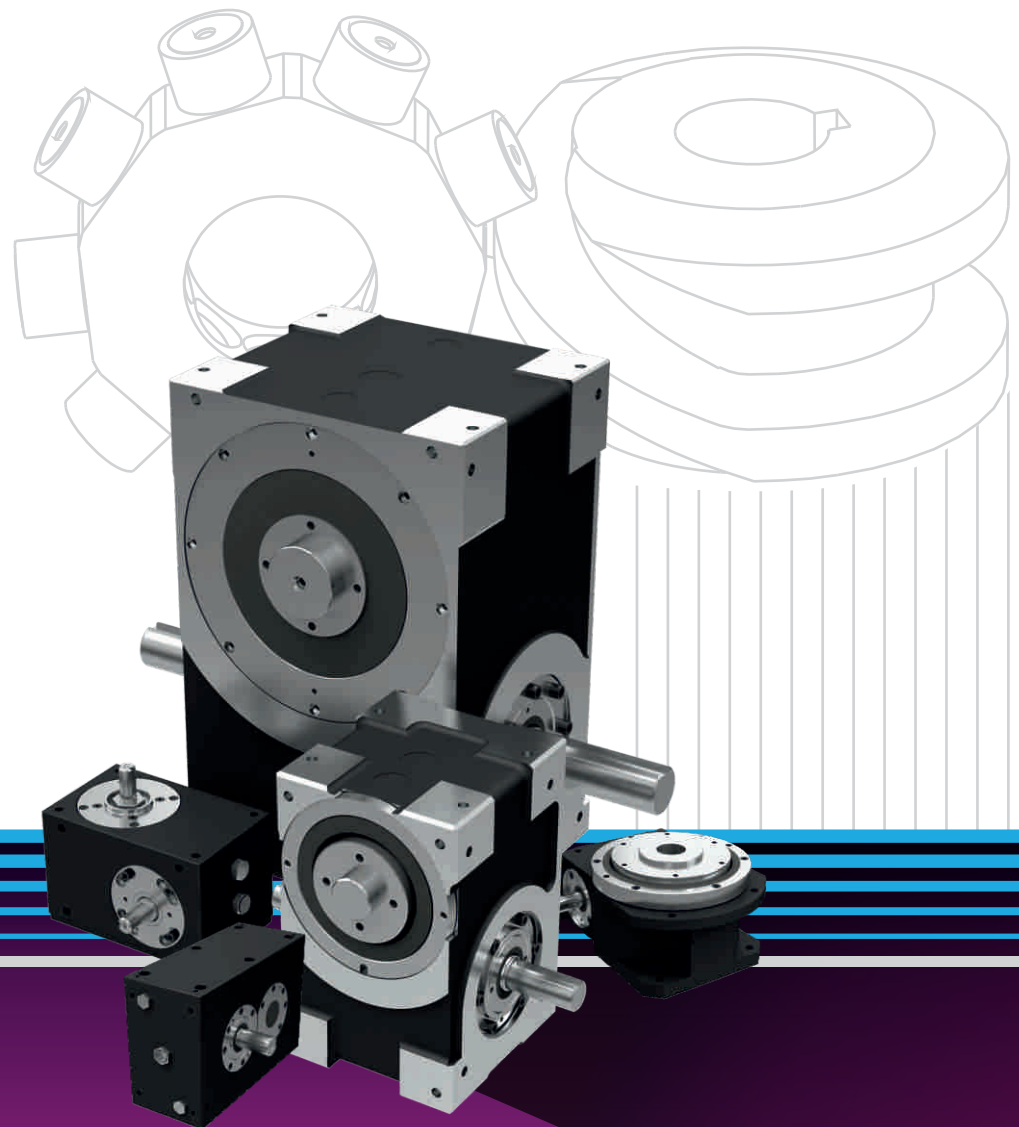

CAM INDEXERS FOR INTERMITTENT MOTION CONTROL

The key component of any production process is accurate and fault free operation for a very long time. Packam products ensure this can happen in your product every time.

The drives manufactured by Packam Controls are mechanical indexing units or oscillating mechanisms used to transform the constant speed rotary motion of the input shaft into intermittent one-way or oscillating movement of the output shaft by way of a cam drive profile and followers. Once the motion profile is decided and manufactured it cannot be changed unless the indexing mechanism is exchanged. An exception is the servo-driven indexing unit with a backlash-free, constant velocity globoidal cam mechanism.

The size of the indexing unit is determined by analysing the forces resulting from the load, velocity and the acceleration/deceleration forces. Packam has many years of experience in the selection of the right indexer size and can therefore serve its customers in the best possible way. If all required application data is accurately provided & sizing is done by Packam, this shall result in Optimum Model Selection ensuring desired performance & life of indexer.

Mechanical indexing units and indexing drives with globoidal cams or flat cams have a high reliability and virtually zero maintenance during a long service life. They are available as cycle-on-demand or continuous run drives. Depending on the application, there may be need for protecting the indexer/oscillator from overload on either the input or the output side of the indexer. Overload clutches can be installed to protect the indexing drive unit in emergency situations (failure in the power supply, blockage through external influences, interfering motions). On request, Packam can deliver indexing units complete with motor and gear units of any type selected by the customer.



Packam has many years of experience in design and manufacture of indexers. All the materials and hardware used are from reputed manufacturer. Our cams are through hardened and ground to micron accuracy with a very high surface finish. Our specially designed high-performance cam followers have better performance under specified working parameters. The assembly process has been mastered by our technicians to ensure that the indexer is delivered in ready-to-use condition.

Packam offers a wide range of indexing devices for all your automation needs. They are used by a larger segment of industry, for example: Assembly Automates, Automotive, Cartoning Machines, Feeding Mechanisms, Indexing Conveyors, Packaging Machinery, Part Transfers, Pharmaceutical Machines, Printing Machinery, Solid & Liquid Filling Machines, Welding Automation, Special Purpose Machines and many more...

TYPES OF CAM LAWS

Packam drives make use of standard motion laws such as modified sine, modified trapezoid, cycloidal, etc... But that's not all. We can easily design custom mechanisms to your individual requirements. We can even provide combinations of standard and special acceleration laws to produce unique motions. In most cases, you can select any index/dwell ratio and the number of stops needed.

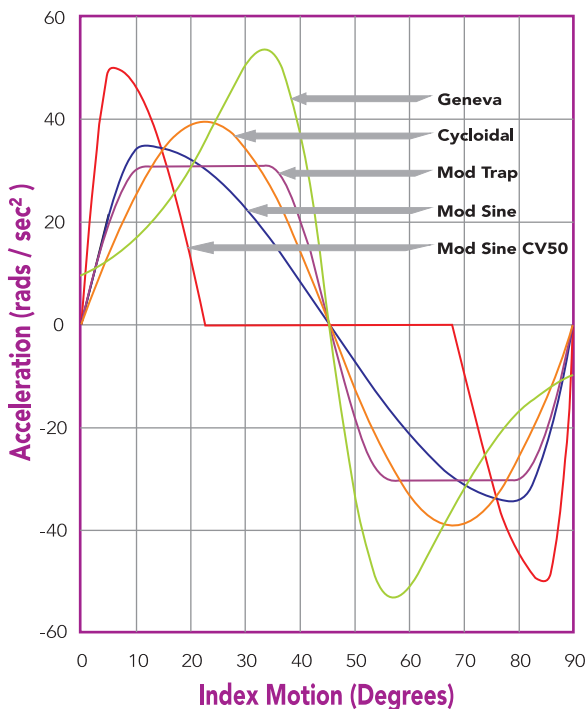

TYPES OF CAMS



TYPES OF MOTIONS

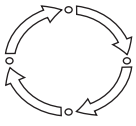

Index Drives

Indexing drives stop and move or "index" intermittently according to the following pattern:

dwell - index - dwell - index



Oscillating Drives

An oscillating drive has an output shaft that reciprocates back and forth motions or swings, with a continuous and consistent rotation.

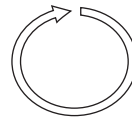

Continuous Drives

Continuous drives are speed reducers used where smooth rotation and high torque output is required without any drive loss or backlash.

PRODUCT RANGE

Packam offers a wide range of indexing devices for all your automation needs. If you are looking for accurate, reliable, long-lasting automation equipment, Packam has the solution.

Globoidal Cam Indexers

GC50	GC80	GC95	GC110	GC140	GC150	GC180	GC200	GC250
◆ 54mm	80mm	95mm	108mm	140mm	152mm	178mm	200mm	254mm

Rotary Table Indexers

	RT85	RT100	RT150	RT240
	◆ 85mm	108mm	152mm	240mm

Heavy Duty Indexers

	HD190	HD265	HD315
	◆ 190mm	267mm	315mm

Parallel Cam Indexers

PC40	PC50	PC63	PC80	PC100	PC125	PC160	PC200	PC250
◆ 40mm	50mm	63mm	80mm	100mm	125mm	160mm	200mm	250mm

For model specific technical details, kindly refer to our Technical Product Catalogue. Contact our Sales Team for a copy.

◆ C.D. - Centre distance between the input & output shaft of the indexer.

OPTIONAL FEATURES

Output Shaft

- Flange output is standard on most models
- Shaft output and Hollow output with through hole available on request

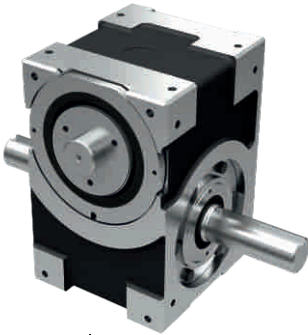

Flange output

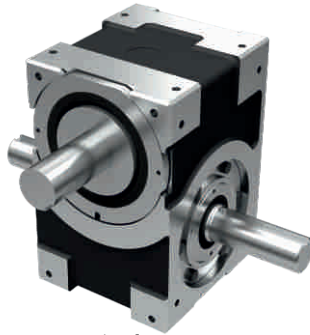

Shaft output

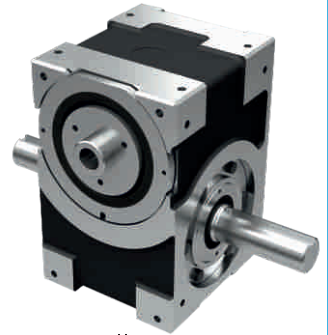

Hollow output

Input Shaft

- Double ended input shaft is standard on most models - single ended input shaft also available on request
- Customised input shaft to mount geared motor available on request

Drive Package

- Most models are available with a high performance drive package including: indexer, worm gear (with or without brake & integral slipping clutch) and AC motor.

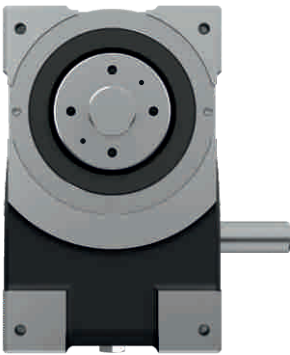

Single Ended Shaft

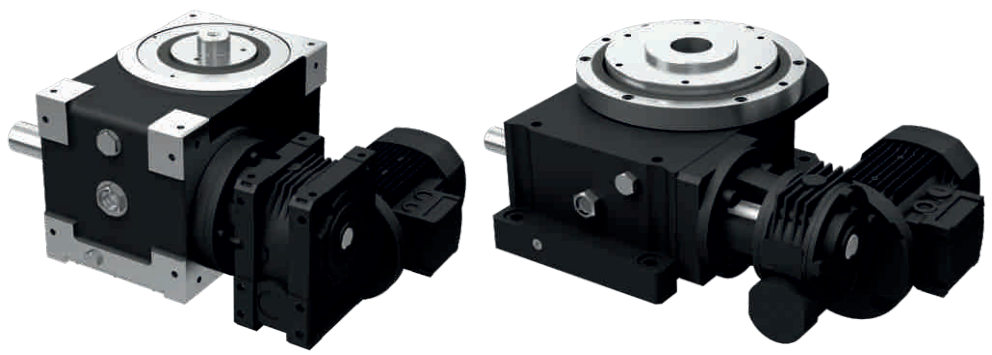

Drive Package

ADD-ONS

Add-ons for Cycle-On-Demand applications available on request

- Actuator cam
- Sensor
- Bracket

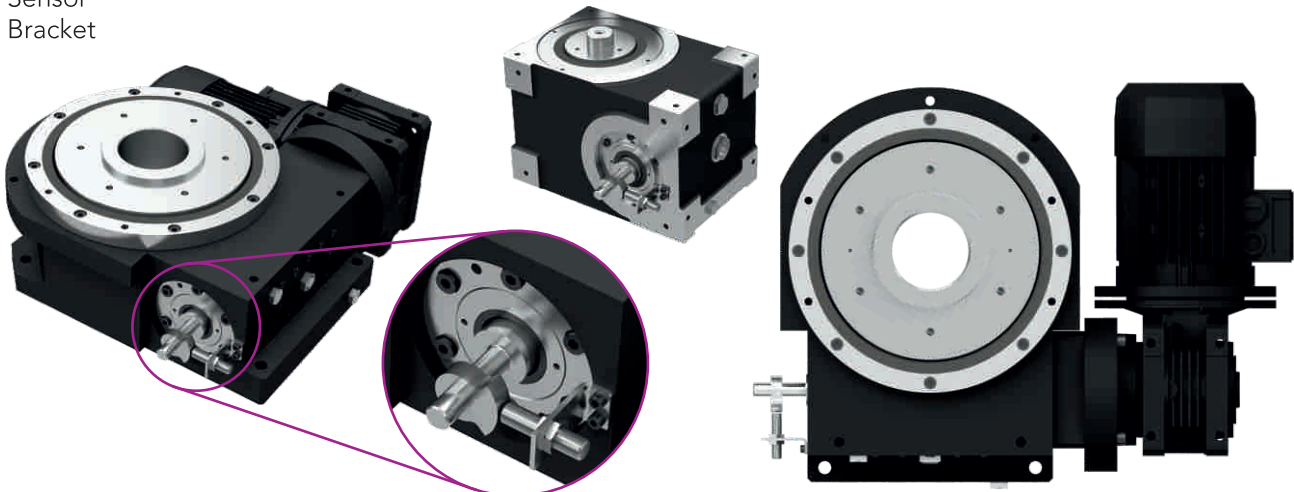

GC TYPE - Globoidal Cam Indexers

Right angle indexers are typically used for continuously running applications with cams designed to match the indexing and idle times without stopping the motor. These are versatile units suitable for a wide range of applications.

Features:

- o Through hardened and CNC ground steel cam
- o Cast iron housing for rigidity and zero vibration
- o Shaft and hollow output are optional on most models
- o Double dwell cam for high speed indexers

Technical Specifications:

Models:	GC50	GC110	GC180
	GC80	GC140	GC200
	GC95	GC150	GC250
Number of stops:	(0) 1 to 32 "0" equals constant speed cam (CV)		
Indexing angles:	90° to 330° (depending on number of stops)		
Oscillating angle:	upto 150° indexing angle (special motion profiles possible)		

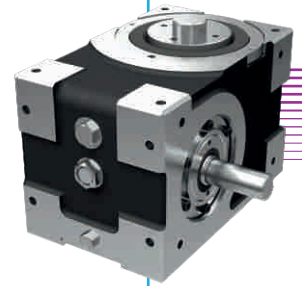

DRIVES



MOTION



SUPPORT



MECHANISM



CUSTOMISATION



Servo
Mechanical Indexer

Also available as servo-mechanical indexer for precise control and flexibility



RT TYPE - Rotary Table Indexers

Rotary indexing units with globoidal cam mechanisms are ideal for dial plate indexing. It features low profile cast iron housing having through bores for routing supply lines. Large output mounting surface supported by bearings offers superior thrust and moment capacity.

Features:

- o Through hardened and CNC ground steel cam
- o Cast iron housing for rigidity and zero vibration
- o High degree of stability for dial plate applications
- o Through hole for wires and utilities
- o Large output flange

Technical Specifications:

Models:	RT85	RT150
	RT100	RT240
Number of stops:	(0) 3 to 32 "0" equals constant speed cam (CV)	
Indexing angles:	90° to 330° (depending on number of stops)	
Oscillating angle:	Limited possibilities (depending on output angle)	



DRIVES



MOTION



SUPPORT



MECHANISM



CUSTOMISATION



Servo
Mechanical Indexer

Also available as servo-mechanical indexer for precise control and flexibility



HD TYPE - Heavy Duty Indexers

HD type indexers are very accurate and reliable rotary tables suitable for heavy duty applications. The robust and compact design provides a big dial plate and a large center hole.

Features:

- o Through hardened and CNC ground steel cam
- o Cast iron housing for rigidity and zero vibration
- o High precision heavy duty cam followers
- o Large output mounting surface
- o Large centre thru-hole

Technical Specifications:

Models:	HD190 HD265 HD315
Number of stops:	(0) 1 to 32 "0" equals constant speed cam (CV)
Indexing angles:	90° to 330° (depending on number of stops)
Oscillating angle:	upto 150° indexing angle (special motion profiles possible)

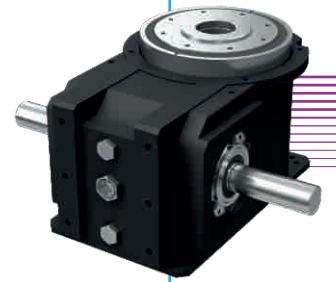

DRIVES



MOTION



SUPPORT



MECHANISM



CUSTOMISATION



Servo Mechanical Indexer Also available as servo-mechanical indexer for precise control and flexibility



PC TYPE - Parallel Cam Indexers

Parallel Cam Indexers (PC Type) have the input and output shafts located parallelly. They are commonly used to drive conveyors when a line shaft needs to index.

Features:

- o Through hardened and conjugate steel cam
- o High precision cam followers
- o Rigid housing - zero vibrations
- o Double ended output shafts are optional on most models

Technical Specifications:

Models:	PC40 PC80 PC160 PC50 PC100 PC200 PC63 PC125 PC250
Number of stops:	1 to 8
Indexing angles:	90° to 330° (depending on number of stops)
Oscillating angle:	up to 45° indexing angle

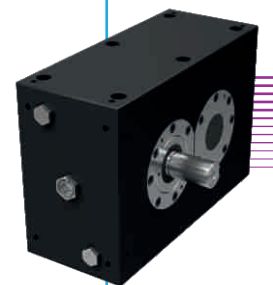

DRIVES



MOTION



SUPPORT



MECHANISM



CUSTOMISATION



CM - Custom Cam Mechanisms

High speeds and productivity rates required by every type of industry nowadays mean that components of intermittent motions in machinery must be driven at smooth, continuous, precise acceleration and speed.

Older technologies like the Geneva Mechanism have limitations and their use is consequently inadvisable today.

- Uncontrolled motion - acceleration and deceleration
- Dynamic shocks
- High maintenance and running costs
- Unknown time and transfer ratios

Packam mechanisms allow accurate design of motion characteristics that fully address the above requirements. These mechanisms are available in standard models or tailor-made to suit customers unique requirements.

Custom sizes and designs available upon request.



CC - Custom Cams

Packam Cams are a better alternative to in-house cam design and manufacturing. Backed by over 20 years of experience, we offer cams in a comprehensive range of configurations, tolerances and materials.

Our designers use the most advanced technologies available to design, manufacture and inspect all cams. We can manufacture a variety of styles as per customer's specific requirements.

Our range of Custom Cams includes:

- Globoidal
- Barrel
- Face-Grooved
- Conjugate
- Flat / Plate

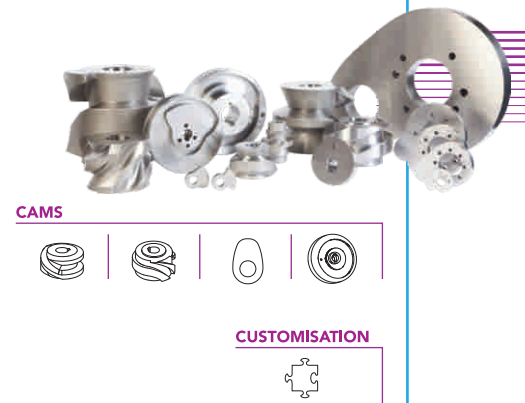

CF - Cam Followers

Packam offers a full range of needle roller cam followers, from 13mm to 101mm outside diameter sizes.

Our Cam Followers are a compact bearing with a high-rigidity shaft and a built-in needle bearing. They are suitable as a guide roller for cam mechanisms and linear motion of automated machines and dedicated machines. Technical innovation and expertise make our cam followers distinctly superior.

Technical Specifications:

Models:	CF13	CF25	CF38	CF64	CF101
	CF16	CF28	CF45	CF68	
	CF19	CF32	CF50	CF76	
	CF22	CF35	CF58	CF90	
Types:	Stud type (GC)		Pin type (PC)		
Series:	Short series (SS)		Long series (LS)		

Custom sizes and designs available upon request.

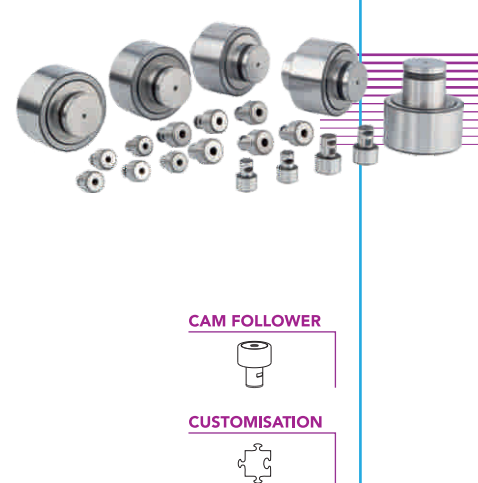

* dimensions and technical information are subject to change without notice
 * kindly refer to Packam warranty and support terms and conditions
 for additional information visit Packam website www.packam.co.in



Packam Controls Private Limited
Patel Vanika, Western Express Highway,
Goregaon (East), Mumbai - 400 063, India

T +91 22 61206600
F +91 22 61206606

E info@packam.co.in
U www.packam.co.in

Domestic Sales Enquiry sales@packam.co.in
International Sales Enquiry export@packam.co.in
After Sales Service service@packam.co.in

